

Holmatro

Spreader SP 5240

Lightweight Strength for Every Rescue



Product Overview

- The Holmatro Spreader SP 5240 is equipped with CORE Technology. The SP 5240 is a lightweight spreader for spreading, squeezing and pulling with one tool.
- Standard supplied with:
 - Carrying Handle with integrated LED lighting
 - Redesigned, ergonomic control handle with improved grip
 - CORE Technology: quicker, safer, easier

Key Features

- **Lightweight, no concessions on performance:**
 - Easy to carry and handle
 - Reducing physical burden
 - Maximum performance at minimum weight
- **Effective profile on the spreading tips:**
 - Perfect grip in every situation
- **Ergonomic carrying handle:**
 - New design increases operator comfort in various working positions
- **New LED lighting in the carrying handle:**
 - No less than six LED lights with a higher light output
 - Rescuers can start their job right away, both during the day and at night, without working in their own shadow
- **New control handle:**
 - Improved ergonomic design, offering better grip for optimal tool control

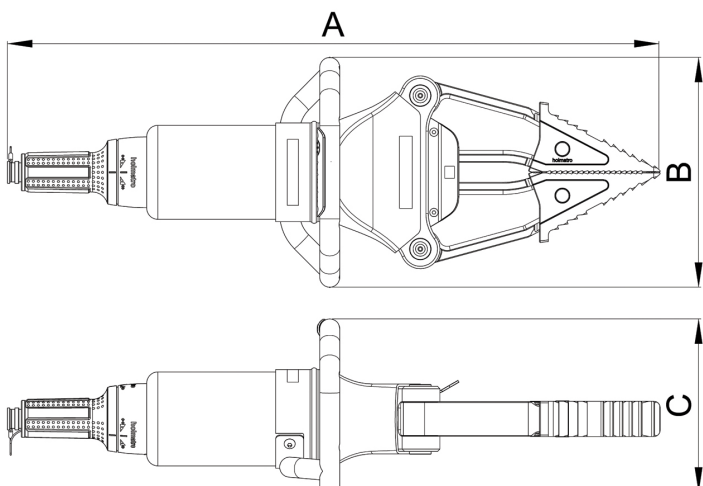

www.frsa.com.au | admin@frsa.com.au | + 61 7 3209 7422

Holmatro

Spreader SP 5240

Lightweight Strength for Every Rescue

Specifications		
Article number		150.012.323
Model		SP 5240
Equipped with (connector type)		CORE
Short description		Spreader
Max. working pressure	bar/Mpa	720 / 72
Spreading distance	mm	725
Max. pulling force	kN/t	47 / 4.8
Pulling distance	mm	610
Max. spreading force	kN/t	280 / 28.6
Theoretical calculated spreading force	kN/t	875 / 89.2
Min. spreading force (EN 13204)	kN/t	41 / 4.2
Max. spreading force, 25mm/1in from the tip	kN/t	93 / 9.5
Max. squeezing force	kN/t	59 / 6
Min. squeezing force (EN 13204 2025 Ed.)	kN/t	24 / 2.4
Required oil content (effective)	cc	226.4
Hydraulic oil type		ISO-L HV VG 15/22
Temperature range	°C	-20 +55
Dimensions (AxBxC)	mm	815 x 286 x 217
Weight (without hose)	kg	14.5
Weight, ready for use (hose connected acc. EN 13204 2025 Ed.)	kg	15.8
EN 13204 classification		AS41/725-14.5
EN 13204 2025 Ed classification		SP3-41/725
NFPA 1960, HPF	kN/t	47 / 4.8
NFPA 1960, HSF	kN/t	70 / 7.1
NFPA 1960, LPF	kN/t	25 / 2.5
NFPA 1960, LSF	kN/t	38 / 3.9
NFPA 1960 compliant		Yes

Safety factors / tests	
Hydraulic safety factor	2:1
Endurance test tool	1000 cycles of opening and closing while arms are loaded
Endurance test dead man's handle	6000 cycles

Standard supplied with
<ul style="list-style-type: none"> • Carrying handle with integrated LED lighting • Redesigned, ergonomic control handle with improved grip • CORE Technology: quicker, safer, easier

Accessories	
Cutting Tip Set CTS 01	150.006.474
Spreading Tip Set STS 02	150.006.475
Pulling Attachment Set PAS 02	150.182.274
Pulling Chains Set in Case PCS 02	150.582.021
Pulling Chains Set PCS 01	150.582.152

